

Series 5100 Hermetically Sealed Immersion-Type Thermostats

An outstanding feature of Series 5100 Immersion-Type Thermostats is the all stainless steel construction. The T.I.G. welded, hermetically sealed case ensures meeting high shock and vibration requirements.

The unit is a two-terminal, isolated case thermostat based on a single throw, snap-action, bimetallic disc which provides quick and positive switching. The temperature sensing element is located in the extreme end of the stainless steel tube to provide maximum thermal conductivity, offering rapid response to liquid or air temperature variations.

Typical applications include hydraulic systems, degreasers, industrial and portable air compressors, engine generator sets, chemical baths, engine coolant, oil and transmission protection.

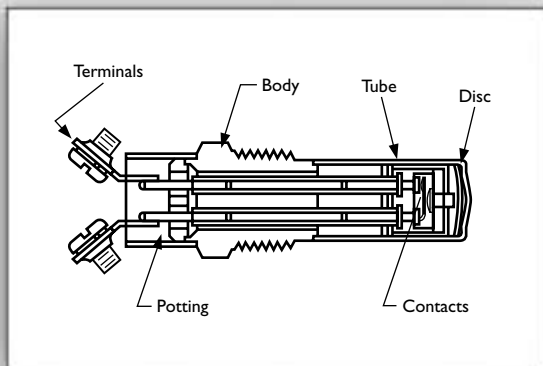

SPECIFICATIONS

- **Operating Temperature Range:**
35°F to 500°F (1.7°C to 260°C)
- **Tube Temperature Exposure Limits:**
Available from -40°F to 550°F (-40°C to 288°C)
Note: Please consult the factory if lead wire/terminal exposure temperatures are expected to exceed 220°F. (Refer to inside notes B&C)
- **Shock:** .75G 6ms duration (sawtooth)
- **Vibration:** .06DA, 10-55Hz, 20G 55-2000Hz
- **Contact Rating for 100,000 Life Cycles:**
3 amp resistive, 32Vdc/120Vac 60Hz
1.5 amp 240Vac 60Hz
125Vac pilot duty to 240Vac 60Hz
- **Contact Rating for 6000 Operations:**
5 amp resistive 120Vac 60Hz
2-1/2 amp resistive 240Vac 60Hz
- **Dielectric Strength:**
1800V RMS 60Hz, Terminals to case
- **Insulation Resistance:** 60 megohms at 500 Vdc
- **Thermal Shock:** MIL-STD-202, Method 107 Test Condition B
- **Pressure Exposure Limit:** Standard Tube will withstand 1500 PSI Maximum. Higher pressure ratings available upon request.
- **Approval File Numbers:** UL E36687 and E66685. CSA LR25561-5 and LR25561-8.

MATERIALS

- **Body and Tube:** Stainless steel
- **Seal:** Compression glass
- **Potting:** Mylar sleeve, epoxy fill
- **Terminals:** Stainless or plated steel
- **Contact:** Fine silver

AIRPAX®

© Copyright 2000 Airpax · All Rights Reserved · 00098 2/00

SELECTION CODE CHART

A Contact Operation

Choose from codes below for specific contact operation.

CONTACT OPERATION

Code O = Open on Rise

Code C = Close on Rise

B Basic Series Number

Code 51 for all variations of this thermostat.

To establish your Airpax Thermostat Part Number precisely, choose the proper code letter from the following tables for terminal selection and mounting. Then complete your selection code chart by using temperature specification tables.

HOW TO USE THIS CHART

Each thermostat P/N (Part Number) consists of functional “building blocks” to enable the user to specify clearly and precisely the desired characteristics in each selection category. Select the proper Code in each category, then transfer it to “Your PN” boxes to the right. Unless a special requirement (Code Z) is indicated, the entries in “Your PN” boxes will accurately specify a standard catalog item.

When Code Z is used, special features (not specified herein) or a unique part number is required, the last four digits from the part number (bottom temperature and tolerance) will be eliminated and a unique four digit number assigned by Airpax will be inserted. The example shown, records a selection of a standard item with a typical code specified in each “building block” category.

EXAMPLE PN:

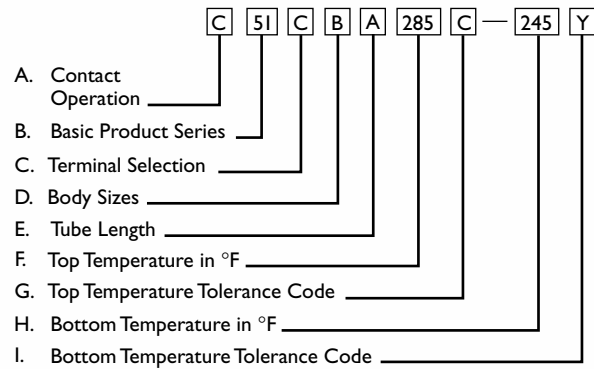

YOUR PN:

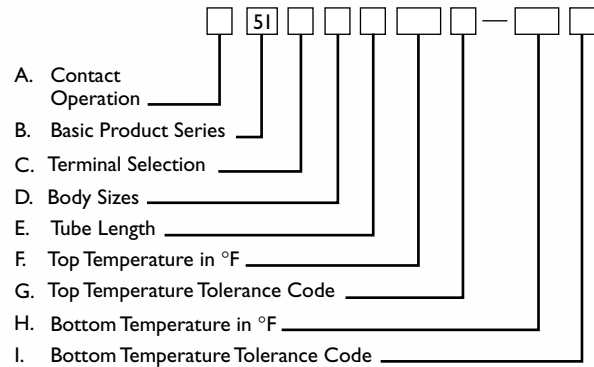

NOTES

- The marking information on each thermostat will be on the hex or sensing tube and include the trade name Airpax, contact operation (CLR) close on rise, (OPR) open on rise, top temperature and date code.
- The standard lead wire material for different temperature ranges is as follows:
 - A.** Up to 220°F (104.4°C) - #18 stranded UL 1015/CSA approved (PVC insulation - color black)
 - B.** 221°F to 350°F (105°C to 176.6°C) - #18 stranded UL 1199/CSA approved (TFE insulation - color black)
 - C.** 351°F to 500°F (177.2°C to 260°C) - #18 stranded (Teflon, ceramic and glass composite insulation - color brown)



C Terminal Selection

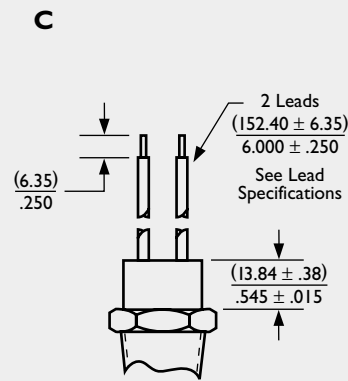
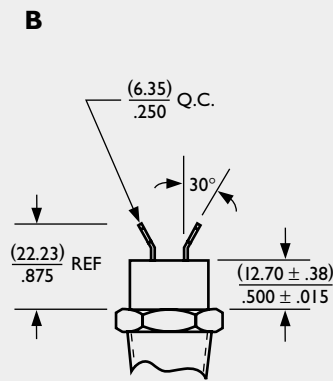
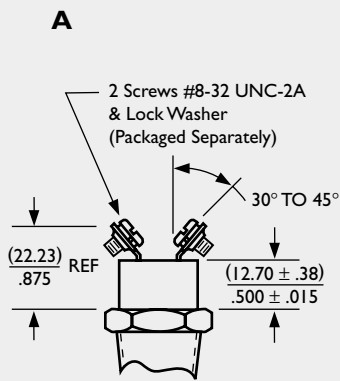

D Same as Terminal Selection "C"
 Except Lead (304.80 ± 25.40) / 12.00 ± 1.00
 (See Notes A, B and C for Lead Wire Specifications)

E Same as Terminal Selection "C"
 Except Lead (609.60 ± 25.40) / 24.00 ± 1.00
 (See Notes A, B and C for Lead Wire Specifications)

F Same as Terminal Selection "C"
 Except Lead (1219.20 ± 25.40) / 48.00 ± 1.00
 (See Notes A, B and C for Lead Wire Specifications)

Z Special Requirements; Customer to Specify

D Body Sizes

(Note: All sensor tubes attached to end indicated by £)

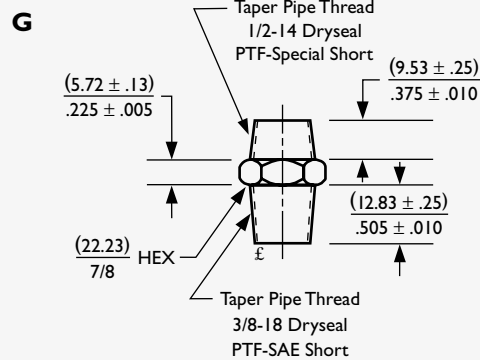
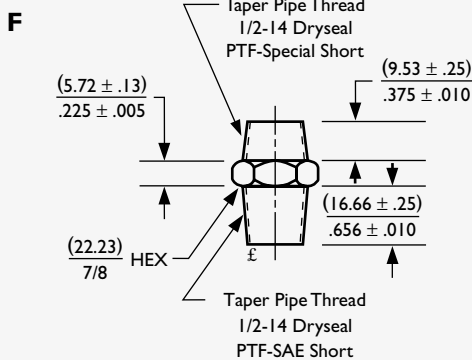
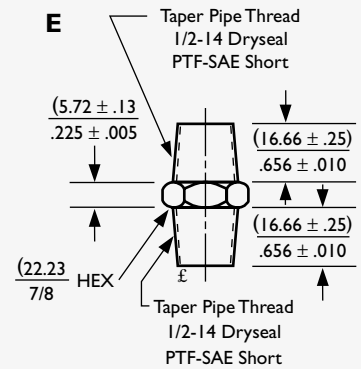
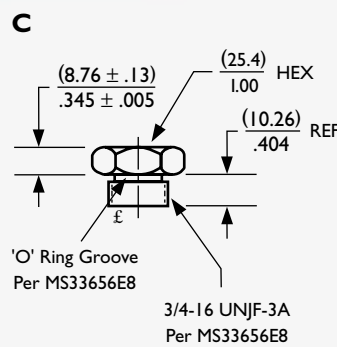
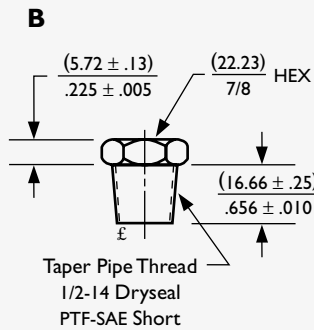
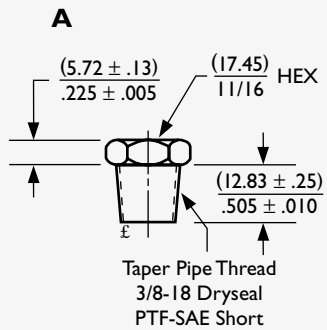

Z Special Requirements; Customer to Specify

E Tube Lengths

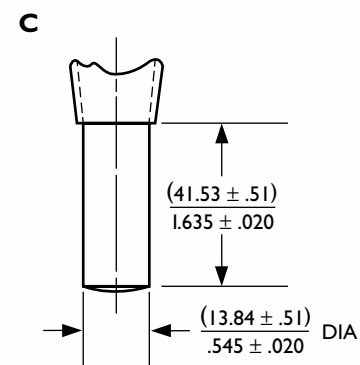
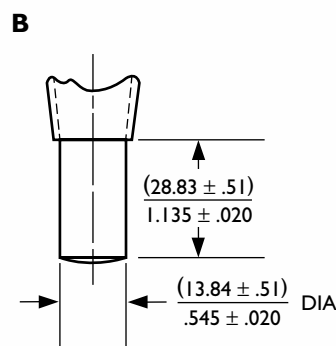
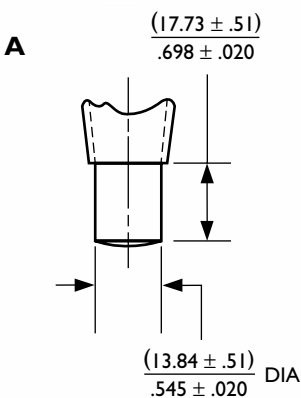

Z Special Requirements; Customer to Specify

TEMPERATURE SPECIFICATIONS

To complete your part number on Airpax Series 5100 Thermostats, the following information and charts will allow completion of “building blocks” F, G, H and I.

Table 1

OPERATING TEMPERATURE SETTINGS

	°F	°C	°F	°C	°F	°C
Temperature Setting	+35° to +250°	+1.7° to +121.1°	+251° to +400°	+121.6° to +204.4°	+401° to +500°	+205° to +260°
Standard Tolerance	±5°	±2.8°	±10°	±5.6°	±25°	±14°
Standard Nominal Differential	20	11.2	40	22.4	60	33.5

Table 2

STANDARD TEMPERATURE TOLERANCE CODE FOR PART NUMBER SELECTION

CODE	A	C	N	X	Y
±°F	5	10	25	Maximum	Minimum
±°C	2.8	5.6	13.9	Maximum	Minimum

F Top Temperature in °F

Select any temperature in the range of 35°F to 500°F. See Table 1.

G Top Temperature Tolerance Code

Choose from the codes in Table 2, but don't select a tolerance more restrictive than those specified in Table 1.

H Bottom Temperature in °F

The bottom or reset temperature is obtained by subtracting the Standard Nominal Differential of the applicable range (Table 1) from the Top Temperature selected in step F.

I Bottom Temperature Tolerance Code

Choose from the codes in Table 2, applying the same restrictions used in selecting the Top Temperature Tolerance in step G. A minimum temperature is standard (“Y” designation).

Temperature set point calibration is checked at the factory with precision test equipment traceable to the U.S. National Institute of Standards and Technology and Proven Methods. Because customer checking methods may differ, a typical variance for correlation is ±2°F (±1.1°C).

It is the customer's responsibility to determine whether the product is proper for customer's use and application.

This information is subject to change without notice.



©Copyright 2000 Airpax · All Rights Reserved · 00094 2/00

Airpax Corporation · Thermal Sensing Products
 550 Highland Street · Frederick, MD 21701 · USA
 TEL: 301.663.5141 · FAX: 301.698.0624 · www.airpax.net